



后芮驷(上海)电子有限公司

Horus International Electronics Co., LTD.

承认书

SPECIFICATION FOR APPROVAL

编号:

品名	DESCRIPTION:	汽车阵列片式电阻
规格	SPEC :	HRS-QRAXXXXXXXXXXXXXXZ
包装	PACKAGE:	卷装
客户	CUSTOMER:	
客户料号	CUSTOMER P/N:	

APPROVED BY	
CUSTOMER	 HORUS



QRA-Series Automotive Array Chip Resistor Product Specifications

Document No.	S-10-12-21-07
Released Date	2022/06/10
Page No.	1/9

■ Automotive Array Chip Resistor — QRA Series

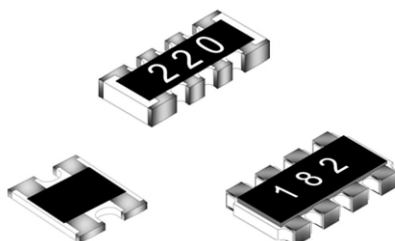

■ Application

- Automotive electronics
- Navigation equipment, TPMS
- Heating, Ventilating and Air conditioning
- Indoor lighting, Central door locking, Wiper module

■ Features

- Small size and light weight
- Reliability, high quality
- CCD visual quality inspection
- AEC-Q200 Compliance

■ Parts Number Explanation

■ Example:

QRA	024R	J	10R0	P	05	Z
Product Type	Size (Inch)	Resistor Tolerance	Resistor Value	Package	Quantity	Optional
QRA	022R(0402*2) 024R(0402*4) 034R(0603*4) 064R(1206*4)	F : ±1% J : ±5%	1R=1R00 10R=10R0 100R=100R 1K=1K00 1M=1M00	P : Paper Taping (034R) Q : Paper Taping (022R, 024R) E : Embossed Taping	04 : 4000PCS 05 : 5000PCS 10 : 10000PCS	Z:default



QRA-Series Automotive Array Chip Resistor Product Specifications

Document No.	S-10-12-21-07
Released Date	2022/06/10
Page No.	2/9

■ Standard Electrical Specifications

Type \ Item	Rating Power at 70°C	Max Working Voltage	Max Overload Voltage	T.C.R. (PPM/°C)	Resistance Range
					F(±1%) · J±(5%)
QRA022R	0.063 W	25V	50V	±400	$1\Omega \leq R < 10\Omega$
				±200	$10\Omega \leq R \leq 1M\Omega$
QRA024R	0.063 W	25V	50V	±400	$1\Omega \leq R < 10\Omega$
				±200	$10\Omega \leq R \leq 1M\Omega$
QRA034R	0.1 W	50V	100V	±400	$1\Omega \leq R < 10\Omega$
				±200	$10\Omega \leq R \leq 1M\Omega$
QRA064R	0.25 W	200V	400V	±400	$1\Omega \leq R < 10\Omega$
				±200	$10\Omega \leq R \leq 1M\Omega$

- For non-standard parts, please contact our sales dept.
- Operating Temperature Range : -55°C ~ +155°C.

Type	022R	024R	034R	064R
Jumper Rated Current	1A			2A

■ Type Dimension

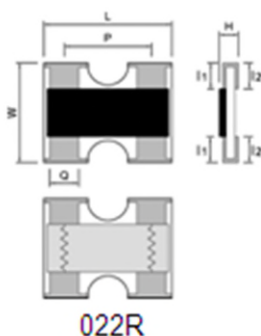
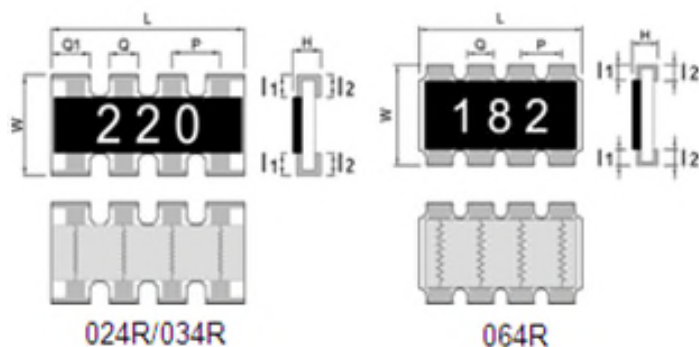

■ Dimension

Unit: mm

TYPE	L	W	H	I ₁	I ₂	P	Q	Q1
QRA022R	1.00±0.10	1.00±0.10	0.33±0.05	0.15±0.10	0.25±0.10	0.67±0.10	0.34±0.10	---
QRA024R	2.00±0.10	1.00±0.10	0.40±0.10	0.20±0.10	0.20±0.10	0.50±0.10	0.30±0.10	0.43±0.10
QRA034R	3.20±0.20	1.60±0.15	0.50±0.10	0.30±0.20	0.30±0.20	0.80±0.20	0.50±0.15	0.61±0.10
QRA064R	5.10±0.20	3.10±0.20	0.55±0.15	0.55±0.15	0.55±0.15	1.30±0.20	0.90±0.10	---

● General Information

■ Recommend Land Pattern Design (For Reflow Soldering)

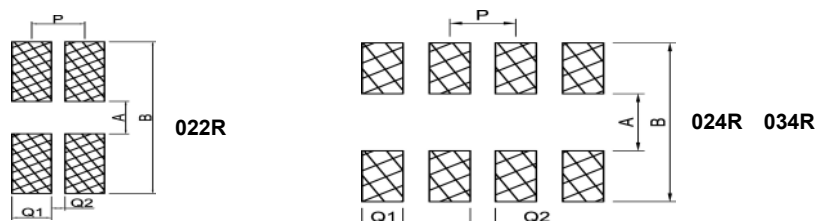

■ Dimension

Unit: mm

Type	022R	024R	034R	064R	
Item	A	0.50	0.50	1.00	2.00
B	2.00	2.00	2.60	4.75	
P	0.67	0.50	0.80	1.30	
Q1	0.33	0.28	0.40	0.90	
Q2	0.34	0.22	0.40	0.375	

■ Performance Characteristics

■ Power Derating Curve

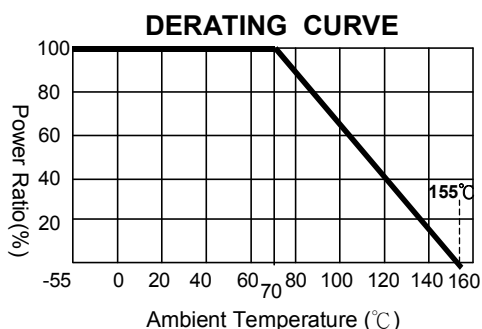

Power rating or current rating is in the case based on continuous full-load at ambient temperature of 70°C. For operation at ambient temperature in excess of 70°C, the load should be derated in accordance with figure of derating Curve.

■ Voltage Rating or Current Rating

Resistance Range: $\geq 1\Omega$

Rated Voltage: The resistor shall have a DC continuous working voltage or a RMS AC continuous working voltage at commercial-line frequency and wave form corresponding to the power rating, as determined formula as following:

$$E(RCWV) = \sqrt{P \times R}$$

E=Rated voltage(V)
P=Power rating(W)
R=Nominal resistance(Ω)



QRA-Series Automotive Array Chip Resistor Product Specifications

Document No.	S-10-12-21-07
Released Date	2022/06/10
Page No.	5/9

● Reliability Test and Requirement

Test Item	Test Method	Procedure	Requirements
Temperature Coefficient of Resistance (T.C.R)	JIS-C-5201-1 4.8 IEC-60115-1 4.8	At 25°C / -55°C and 25°C / +155°C, 25°C is the reference temperature	As Spec
Short Time Overload	JIS-C-5201-1 4.13 IEC-60115-1 4.13	2.5 times RCWV or Max. Overload voltage whichever is less for 5 seconds.	±1 : ±(1.0%+0.05Ω) ±5 : ±(2.0%+0.1Ω)
Leaching	JIS-C-5201-1 4.18 IEC-60068-2-58 8.2.1	260±5°C for 30 seconds.	>95% Coverage
Resistance to Soldering Heat	JIS-C-5201-1 4.18 IEC-60115-1 4.18	260±5°C for 10 seconds.	±1 : ±(0.5%+0.05Ω) ±5 : ±(1.0%+0.05Ω)
Insulation Resistance	JIS-C-5201-1 4.6 IEC-60115-1 4.6	Apply 100VDC for 1 minute.	≥ 10GΩ
Temperature Cycling	JESD22 Method JA-104	1000 Cycles (-55°C to +125°C) Measurement at 24±4 hours after test conclusion. 30min maximum dwell time at each temperature extreme.	1% : ±(0.5%+0.05Ω) 5% : ±(1.0%+0.10Ω)
Resistance to Solvent	MIL-STD-202 Method 215	Add Aqueous wash chemical - OKEM Clean or equivalent.	1% : ±(0.5%+0.05Ω) 5% : ±(0.5%+0.05Ω)
Biased Humidity	MIL-STD-202 Method 103	1,000 hours; 85°C / 85% RH, 10% of operating power. Measurement at 24±4 hours after test conclusion.	1% : ±(1.0%+0.05Ω) 5% : ±(3.0%+0.05Ω)
High Temperature Exposure (Storage)	MIL-STD-202 Method 108	1000 hrs. @ T=155°C. Unpowered. Measurement at 24±4 hours after test conclusion.	1% : ±(0.5%+0.05Ω) 5% : ±(2.0%+0.05Ω)
Operational Life	MIL-STD-202 Method 108	Condition D Steady State TA=125°C at derated power. Measurement at 24±4 hours after test conclusion.	1% : ±(1.0%+0.05Ω) 5% : ±(3.0%+0.10Ω)
External Visual	MIL-STD-883 Method 2009	Electrical test not required. Inspect device construction, marking and workmanship.	—
Mechanical Shock	MIL-STD-202 Method 213	Wave Form : Tolerance for half sine shock pulse. Peak value is 100g's. Normal duration(D) is 6(ms)	±1 : ±(1.0%+0.05Ω) ±5 : ±(2.0%+0.1Ω)
Vibration	MIL-STD-202 Method 204	5 g's for 20 min., 12 cycles each of 3 orientations. Note: Test from 10-2000 Hz	±1 : ±(1.0%+0.05Ω) ±5 : ±(2.0%+0.1Ω)
ESD	AEC-Q200-002 or ISO/DIS 10605	Human body model : 1KV	±(3%+0.05Ω)
Solderability	J-STD-002	(1) 4 hrs 155°C dry heat (2) 245±5°C 3 sec.	±1 : ±(0.5%+0.05Ω) ±5 : ±(1.0%+0.05Ω)
Terminal Strength (SMD)	AEC Q200-006	Pressurizing force for 60 seconds : 8N	No broken
Bending Strength	JIS-C-5201-1 4.33 IEC-60115-1 4.33	Bending once for 5 seconds D : 022R、024R、034R=5mm 064R=3mm	1% and below : ±(1.0%+0.05Ω) 2%、5% : ±(1.0%+0.05Ω)

■ **Recommended Customer Soldering Parameters**

■ **Solder reflow Temperature condition**

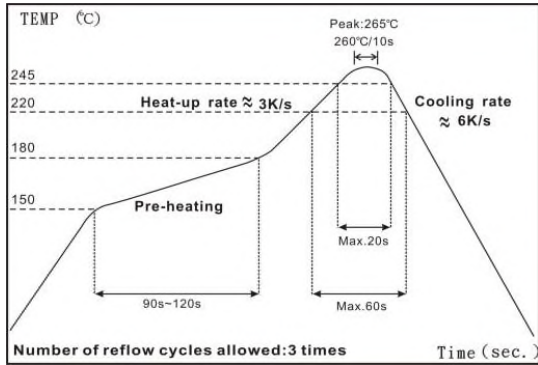

■ **Rework temperature (hot air equipment) : 350°C, 3~5seconds**

■ **Recommended reflow methods**

IR, vapor phase oven, hot air oven

■ If reflow temperatures exceed the recommended profile, devices may not meet the performance requirements

■ **Appendix For SMD Chip Resistor**

● **Packaging Information**

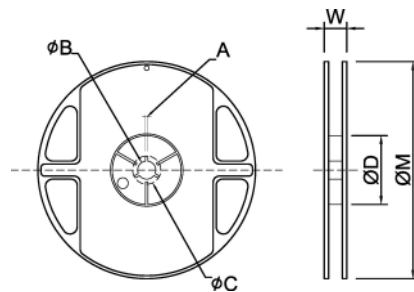

■ **Dimension**

Unit: mm

TYPE	SIZE	A	φ B	φ C	φ D	W	φ M
022R/024R	7"	10K/Reel	2.0±0.5	13.5±1.0	21±1.0	60±1.0	178±2.0
034R	7"	5K/Reel	2.0±0.5	13.5±1.0	21±1.0	60±1.0	178±2.0
064R	7"	4K/Reel	2.0±0.5	13.5±1.0	21±1.0	60±1.0	178±2.0

■ Tapping Specification

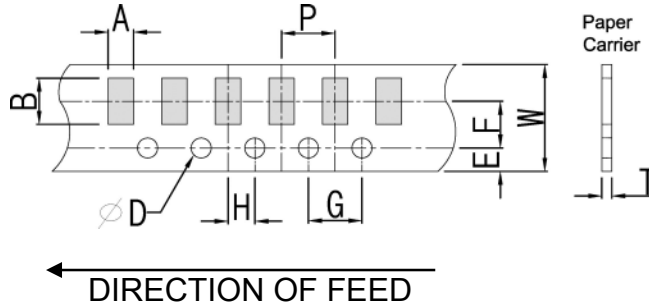

■ Dimension

Unit: mm

Packaging	Type	A	B	W	E	F	G	H	T	ϕD	P
Paper Type	022R	1.25±0.1	1.25±0.1	8.0±0.2	1.75±0.1	3.5±0.05	4.0±0.1	2.0±0.05	0.45±0.1	1.50 +0.10 -0	2.0±0.1
	024R	1.20±0.1	2.20±0.1	8.0±0.2	1.75±0.1	3.5±0.05	4.0±0.1	2.0±0.05	0.60±0.1		4.0±0.1
	034R	1.90±0.2	3.50±0.2	8.0±0.2	1.75±0.1	3.5±0.05	4.0±0.1	2.0±0.05	0.75±0.1		

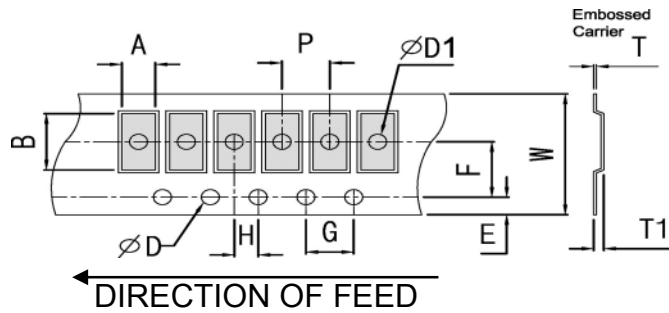

■ Dimension

Unit: mm

Packaging	Type	A	B	W	E	F	G	H	T	ϕD	$\psi D1$	T1	P
Embossed Type	064R	3.55±0.2	5.55±0.2	12±0.3	1.75±0.1	5.5±0.05	4.0±0.1	2.0±0.05	0.25±0.1	+0.10	+0.25	0.85±0.15	4.0±0.1
										-0	-0		

■ Packing Material Data/Storage Data

■ Front & Back Lead Dimension

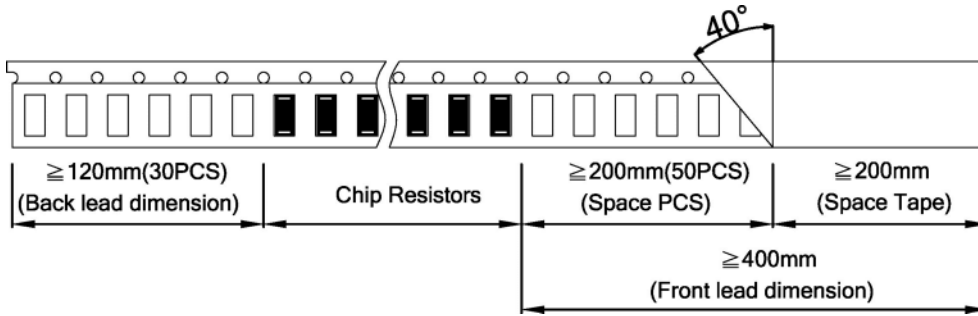

■ Top Adhesive Peel Off Strength : 10~70g

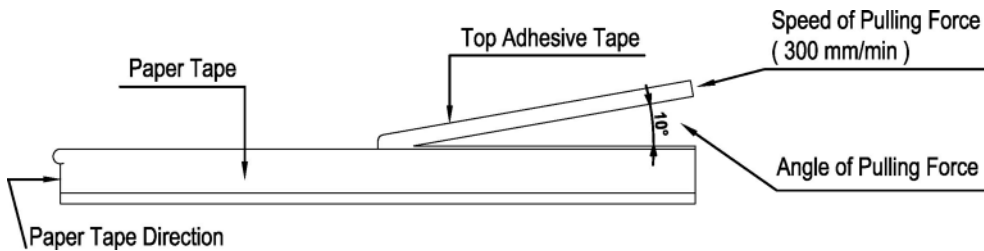

■ Package

Inner Box Size	
Reel	Size H(mm)
1	13
2	24
3	36
5	60
10	113

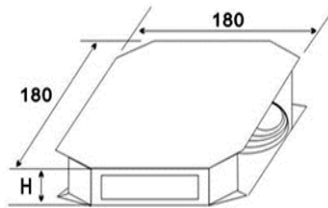

External Box Size			
Contain (Kpcs)	Length (mm)	Width (mm)	Height (mm)
25K	180	180	60
50K	180	180	110
150K	430	200	200
300K	400	400	200

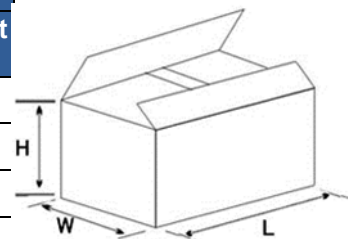

■ Storage Data :

Storage time at the environment temp: 25±5°C & humidity: 60±20% is valid for one year from the date of delivery.

■ Product Testing Method:

Our products are tested with our company's tapping & testing equipments by using four-feet probe to touch at the back of both electrodes. Supposed different testing points or methods are requested, please advise beforehand and customized-made production is available.



QRA-Series Automotive Array Chip Resistor Product Specifications

Document No.	S-10-12-21-07
Released Date	2022/06/10
Page No.	9/9

■ Standard Resistance Values in a Decade

Marking code:

- 5%: marking code, please refer to E24 data
Ex: 120K, The marking code is 124 in E24
- Note: Array resistors 1%&5% code is the same.
- Note: jumper zero ohm resistor marking code is one 「0」 (except type below 022R).

E96	E48	E96	E48	E96	E48	E96	E48	E96	E48						
100	100	169	169	287	287	487	487	825	825						
102		174		294		499		845							
105	105	178	178	301	301	511	511	866	866						
107		182		309		523		887							
110	110	187	187	316	316	536	536	909	909						
113		191		324		549		931							
115	115	196	196	332	332	562	562	953	953						
118		200		340		576		976							
121	121	205	205	348	348	590	590								
124		210		357		604		E24	E12	E6	E3				
127	127	215	215	365	365	619	619	10	10	10	10				
130		221		374		634		11	12						
133	133	226	226	383	383	649	649	12	12						
137		232		392		665		13	15	15					
140	140	237	237	402	402	681	681	15	15	15					
143		243		412		698		16	18						
147	147	249	249	422	422	715	715	18	18						
150		255		432		732		20	22	22	22				
154	154	261	261	442	442	750	750	22	22	22	22				
158		267		453		768		24	27						
162	162	274	274	464	464	787	787	27	27						
165		280		475		806		30	33	33					
								33	33	33					
								36	39						
								39	39						
								43	47	47	47				
								47	47	47	47				
								51	56						
								56	56						
								62	68	68					
								68	68	68					
								75	82						
								82	82						
								91							

According to IEC publication 63