

***3SM227FMT1KA* AEC-Q103 Qualified**

MEMS Microphone IC

Product Description

The *3SM227FMT1KA* microphone IC are integrated with specialized pre-amplification & analog-to-digital converter ASIC to provide high SNR output from a capacitive audio sensor. It's packaged for surface mounting and high temperature reflow assembly. *3SM227FMT1KA* is ideal in many compact portable consumer electronic devices such as automotive and industrial electronics device.

Features

- AEC-Q100/103 qualified
- Top port
- High stability - no risk of membrane aging
- Suitable for automatic pick-and-place handler and SMT process
- Pulse density modulator (PDM) output interface supports two microphones on a single data line
- Miniature dimension 4.00mm x 3.00mm x 1.06mm
- RoHS/Green compliant
- Sensitivity deviation within ± 1 dB
- Package type : LGA 8-pin
- Omnidirectional

Applications

- Automotive
- Industrial

Table of Contents

Product Description	P.1
Features	P.1
Applications	P.1
Table of Contents.....	P.2
Functional Block Diagram.....	P.3
Pin Definition and Function	P.3
Temperature Range.....	P.3
Acoustical and Electrical Characteristics.....	P.4
Timing Characteristics.....	P.6
Frequency Response.....	P.7
State Diagram.....	P.8
Reliability Qualifications	P.9
Reflow Profile	P.10
PCB Land Pattern Layout	P.11
Application Circuit	P.12
Handling Instructions	P.13
Dimensions	P.14
Package Information.....	P.15
Revision History.....	P.17

Functional Block Diagram

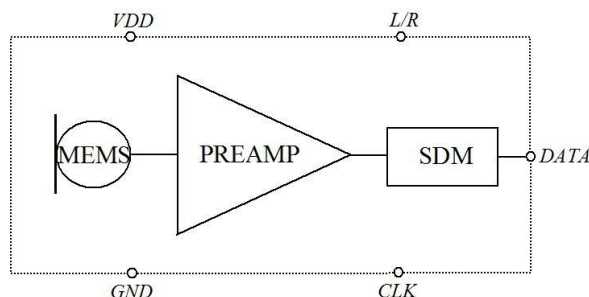

Pin Definition and Function

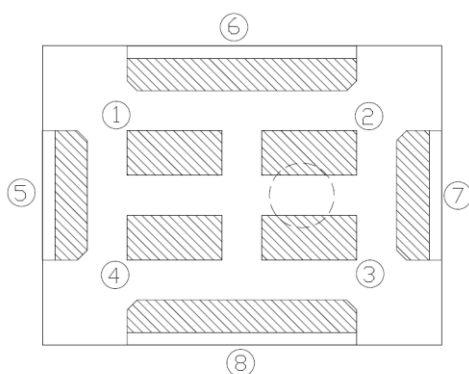

Bottom View

Table 1.

Pin #	Symbol	Type	Function
1	VDD	Power	Power Supply
2	L/R	Non-Digital I	Left(Low) / Right(High) Select Pin
3	CLK	Digital I	Clock Input to Microphone
4	DATA	Digital O	Digital Output Signal
5	GND	Power	Ground
6	GND	Power	Ground
7	GND	Power	Ground
8	GND	Power	Ground

Temperature Range

Table 2.

Storage Temperature	T _{STG}	-40°C ~ 150°C
Operating Temperature Range	T _A	-40°C ~ 125°C

Acoustical and Electrical Characteristics

Table 3. General Microphone Specifications

Typical test conditions are TA = 23 °C, VDD = 1.8V and R.H. = 50 % measured in a pressure chamber test setup. All voltages refer to GND node

Parameters	Symbol	Min.	Typ.	Max.	Unit	Test Conditions
Low Frequency Roll-off	LFRO		38		Hz	-3dB relative to 1KHz
Supply Voltage	Vdd	1.6		3.6	V	
Output Load	C _{Load}			100	pF	
Wake-up Time ⁽¹⁾			100		ms	Fclk ≥ 1MHz
Startup Time			100		ms	
Sleep Time			1		ms	Fclk ≤ 1KHz
Data Format	1/2 Cycle PDM					
Directivity	Omnidirectional					
Polarity	Decreasing density of 1's					Increasing sound pressure

Table 4. Performance Mode Microphone Specifications

Typical test conditions are TA = 23 °C, VDD = 1.8V, Clock=2.4MHz and R.H. = 50 % measured in a pressure chamber test setup. All voltages refer to GND node

Parameters	Symbol	Min.	Typ.	Max.	Unit	Test Conditions
Acoustic						
Sensitivity	S	-27	-26	-25	dBFS	1KHz, 94dB SPL
Signal to Noise Ratio	S/N		60		dBA	A-weighted
Equivalent Noise Level	ENL		34		dBA	A-weighted
Total Harmonic Distortion	THD		<0.2		%	94dB SPL
			1		%	110dB SPL
Acoustic Overload Point	AOP		120		dB SPL	10% THD@1KHz, S = Typ.
Electrical						
Clock Frequency	Fclk	1.0		3.25	MHz	
Current Consumption	I _{sb}		550		μA	Vdd=1.8V
			850		μA	Vdd=3.6V
Power Supply Rejection Ratio	PSRR		60		dBV/FS	1KHz, 200mV peak to peak sine wave on Vcc 2.1V
Power Supply Rejection	PSR+N		-80		dBFS (A)	217Hz, 100mV 1/8 duty cycle peak to peak square wave on Vcc 2.1V, A-weighted

Table 5. Low-Power Mode Microphone Specifications

Typical test conditions are $T_A = 23\text{ }^\circ\text{C}$, $V_{DD} = 1.8\text{V}$, $\text{Clock} = 768\text{KHz}$ and $R.H. = 50\%$ measured in a pressure chamber test setup. All voltages refer to GND node

Parameters	Symbol	Min.	Typ.	Max.	Unit	Test Conditions
Acoustic						
Sensitivity	S	-27	-26	-25	dBFS	1KHz, 94dB SPL
Signal to Noise Ratio	S/N		60		dB	A-weighted
Equivalent Noise Level	ENL		34		dB	A-weighted
Total Harmonic Distortion	THD		<0.2		%	94dB SPL
			1		%	110dB SPL
Acoustic Overload Point	AOP		120		dB SPL	10% THD@1KHz, S = Typ.
Electrical						
Clock Frequency	Fclk	350		800	KHz	
Current Consumption	I _{sb}		300		μA	V _{dd} =1.8V
			400		μA	V _{dd} =3.6V
Power Supply Rejection Ratio	PSRR		60		dBV/FS	1KHz, 200mV peak to peak sine wave on V _{cc} 2.1V
Power Supply Rejection	PSR+N		-80		dBFS (A)	217Hz, 100mV 1/8 duty cycle peak to peak square wave on V _{cc} 2.1V, A-weighted

Table 6. Sleep Mode Microphone Specifications

Typical test conditions are $T_A = 23\text{ }^\circ\text{C}$, $V_{DD} = 1.8\text{V}$, $\text{Clock} = 0\text{Hz}$ and $R.H. = 50\%$ measured in a pressure chamber test setup. All voltages refer to GND node

Parameters	Symbol	Min.	Typ.	Max.	Unit	Test Conditions
Clock Frequency	Fclk	0		250	KHz	
Current Consumption Sleep Mode	I _{sleep}		10		μA	Clock = V _{DD} or GND

(1). Time from the first clock edge to valid output data

Timing Characteristics

Table 7. Microphone Interface Specifications

Parameters	Symbol	Min.	Typ.	Max.	Unit	Test Conditions
Logic Input High	V_{IH}	0.70x VDD		3.6	V	
Logic Input Low	V_{IL}	-0.3		0.30x VDD	V	
Logic Output High	V_{OH}	VDD -0.45		VDD	V	$I_{out} = 1\text{mA}$
Logic Output Low	V_{OL}	0		0.45	V	$I_{out} = 1\text{mA}$
Clock Frequency	F_{clock}			250	KHz	Sleep Mode
		350		800		Low-Power Mode
		1.0		3.25	MHz	Performance Mode
Clock Duty Cycle		40		60	%	
Clock Period for Normal Mode	T_{cyc}	208		1000	ns	
Data Setup Time	T_{dv}			100 ⁽¹⁾	ns	
Data Hold Time	T_{hold}	3 ⁽¹⁾			ns	

(1). Guaranteed by design

Timing Waveforms

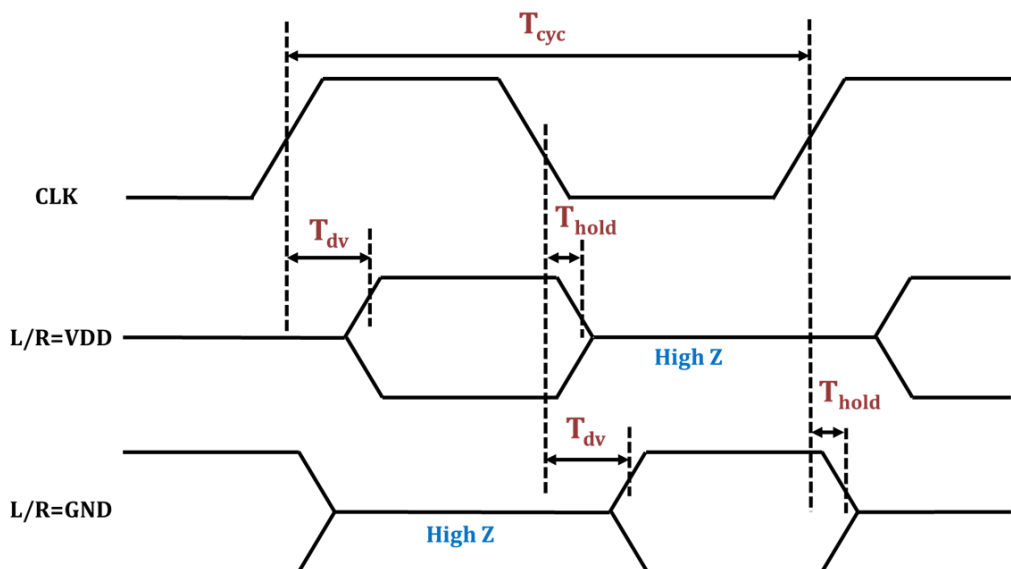

Frequency Response

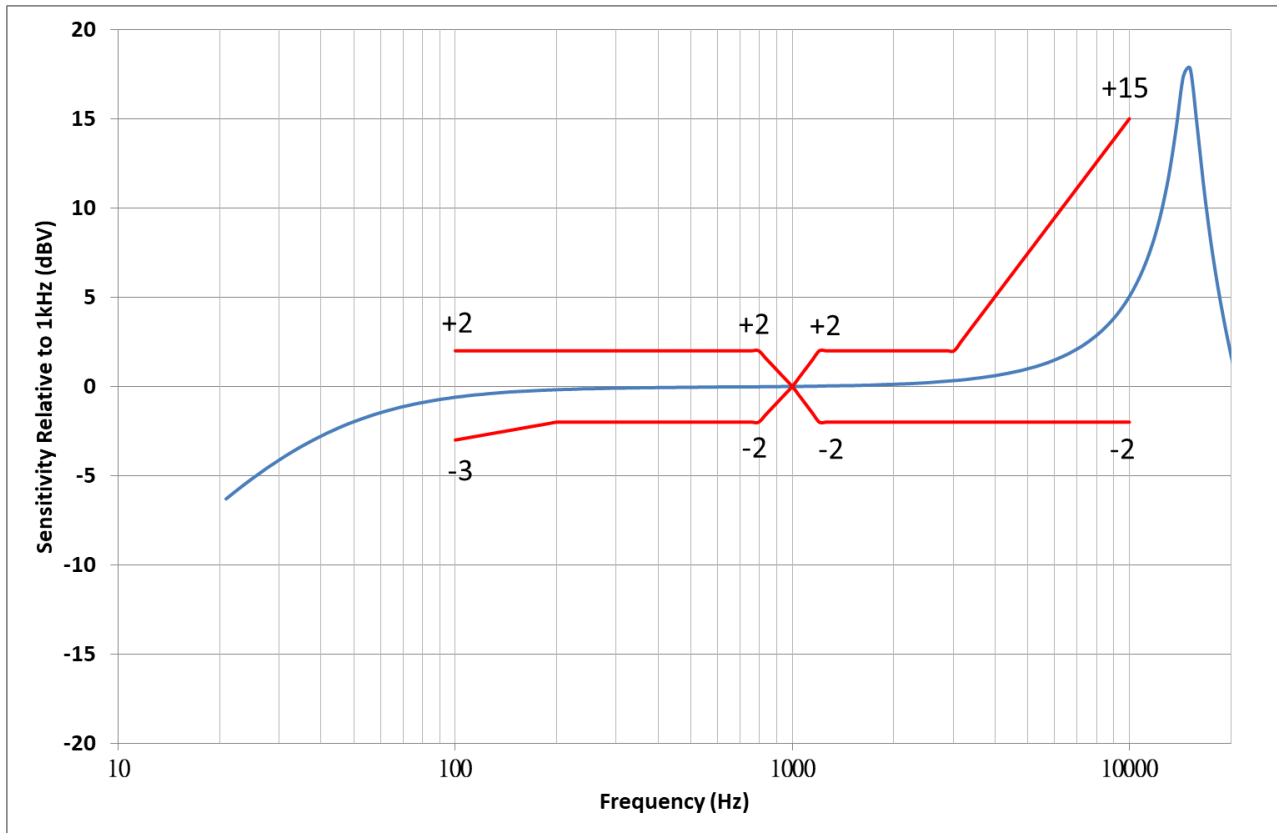

* Measured frequency of 1 KHz

Upper Limit						
Hz	100	800	1000	1200	3000	10000
dB ref. 1KHz	+2	+2	0	+2	+2	+15
Lower Limit						
Hz	100	200	800	1000	1200	10000
dB ref. 1KHz	-3	-2	-2	0	-2	-2

State Diagram

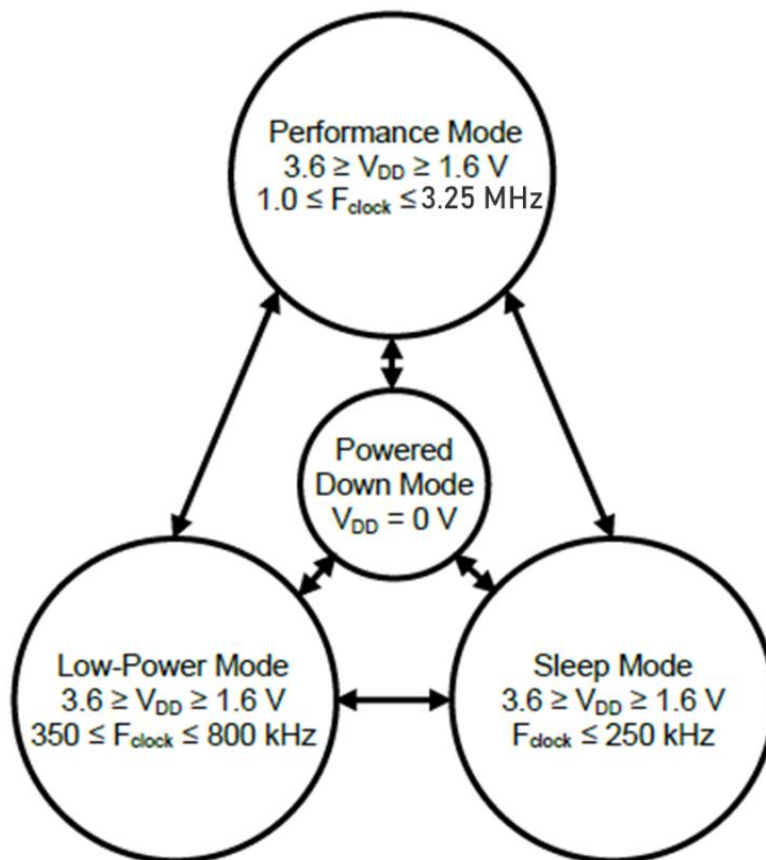

Reliability Qualifications

Table 8.

Test Item	Description	Standard	Result
High Temperature Operating Life	T _A =125°C, V _{CC} =3.6V, 1000hours	AEC Q100 Rev.H	PASS
Low Temperature Operation Life	T _A =-40°C, V _{CC} =3.6V, 1000hours	JESD22-A108	PASS
High Temperature Storage Life	T _A =150°C, 1000hours	AEC Q100 Rev.H	PASS
Low Temperature Storage Life	T _A =-40°C, 1000hours	JESD22-A119	PASS
Pre-Condition	Temperature cycling 5 cycles, Bake 24hrs, Moisture sock 168hrs, Reflow 3 cycles	JESD22-A113	PASS
Temperature Humidity Bias	T _A =125°C, R.H.=85%, V _{CC} =3.6V, 1000hours	AEC Q100 Rev.H	PASS
Thermal Cycling	T _A =-55°C to 150 °C, 1000cycles	AEC Q100 Rev.H	PASS
Humidity & Temperature Cycle	+65°C/90%RH +45°C/95%RH -10°C , 5cycles	AEC Q103-003	PASS
Reflow	Peak temperature = 260°C, 5cycles	J-STD-020	PASS
Variable Frequency Vibration	Peak acceleration 20G, frequency = 20Hz to 2KHz, total 48min duration	AEC Q103-003	PASS
Mechanical Shock	Peak acceleration 10KG, 0.2ms pulse duration, 3 pulses/direction, 6 directions	JESD22-B104	PASS
Package Drop	10 drops on each of 6 faces (total 60 drops) from a high of 1.2m to concrete surface	AEC Q100 Rev.H	PASS
ESD	HBM : All pins, Test Voltage=±3KV	JESD22-A114	PASS
	MM : All pins, Test Voltage=±300V	JESD22-A115	PASS
	CDM : All pins, Test Voltage=±500V	JEDEC JS-002	PASS
	Air Discharge : Test Voltage=±15KV	IEC 61000-4-2	PASS
	Contact Discharge : Test Voltage=±8KV	IEC 61000-4-2	PASS
Latch-up	Class II, T _A =105°C, I=±150mA	AEC Q100 Rev.H	PASS

Notes: Microphones meet all acoustic and electrical specifications before and after reliability testing, except sensitivity which can deviate up to 3dB from its initial value.

After 5 reflow cycles, the sensitivity of the microphone shall not deviate more than 1 dB from its initial value.

Reflow Profile

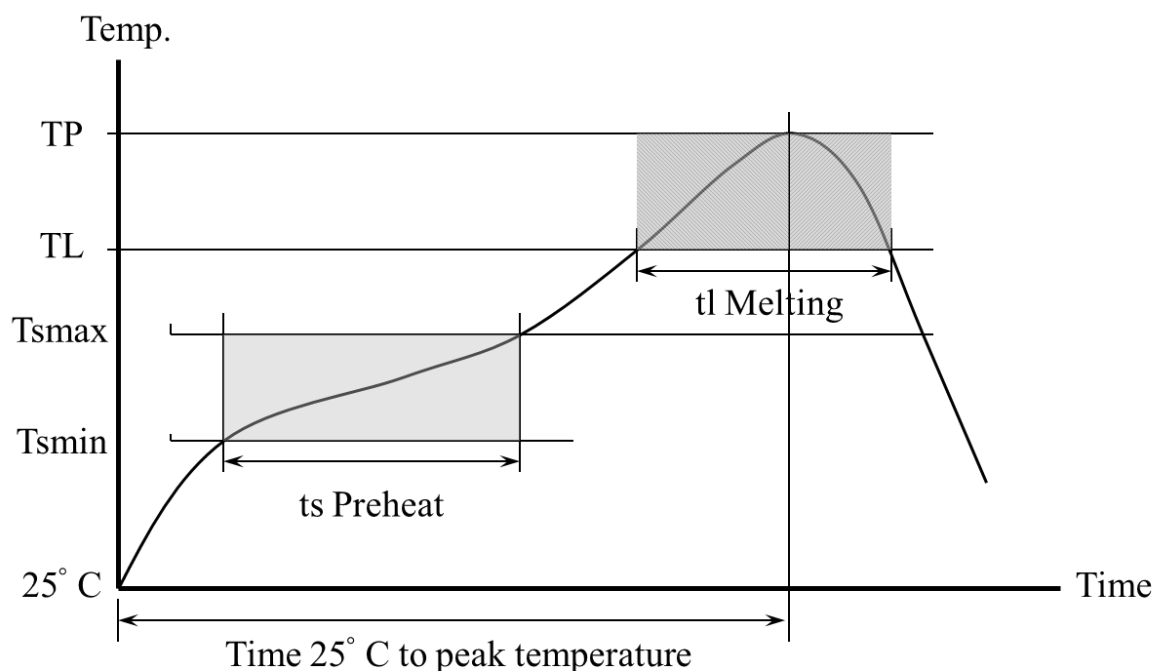

Table 9. Recommended Reflow Profile Limits

Profile Feature	Pb-free
Preheat	
Minimum temperature (Tsmmin)	150 °C
Maximum temperature (Tsmmax)	200 °C
Time (ts)	60~180 sec
Average Ramp up rate (Tsmmax to Tp)	3 °C/sec
Melting area	
Melting temperature (TL)	217 °C
Time maintained above melting (tl)	60~150 sec
Peak Temperature (TP)	260 °C
Time within 5°C of actual peak temperature	20~40 sec
Ramp down rate	6 °C/sec maximum
Time 25°C to peak temperature	8 minute maximum

Notes: Based on IPC/JDEC J-STD-020 Revision F.

All temperatures refer to topside of the package, measured on the package body surface

PCB Land Pattern Layout

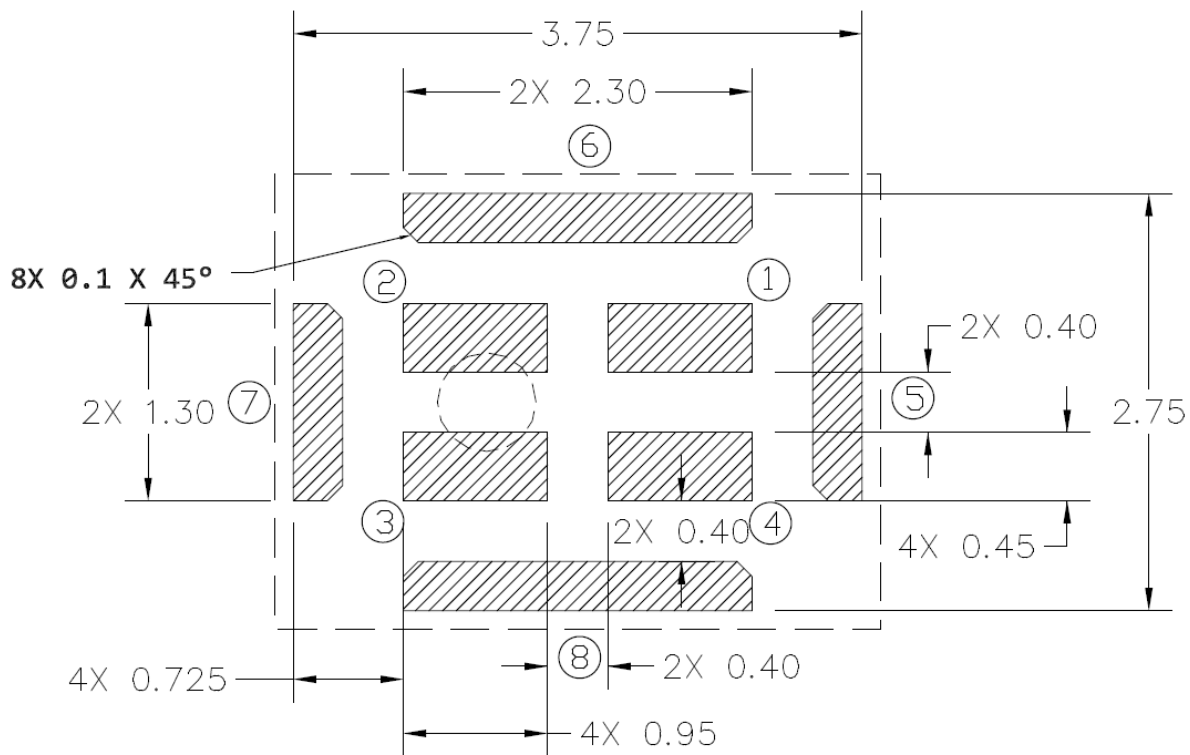

Application Circuit

The L/R pad lets the user to select the DATA signal pattern as explained in Table 7. The L/R pin must be connected to either VDD or GND.

Table 10. L/R channel selection

L/R	CLK low	CLK high
GND	DATA valid	High impedance
VDD	High impedance	DATA valid

Single microphone application:

0.1 μ F ceramic, and 10 μ F ceramic power supply decoupling capacitors should be placed as near as possible to VDD of the device. **The L/R pin must be connected to VDD or GND.**

Two microphones application:

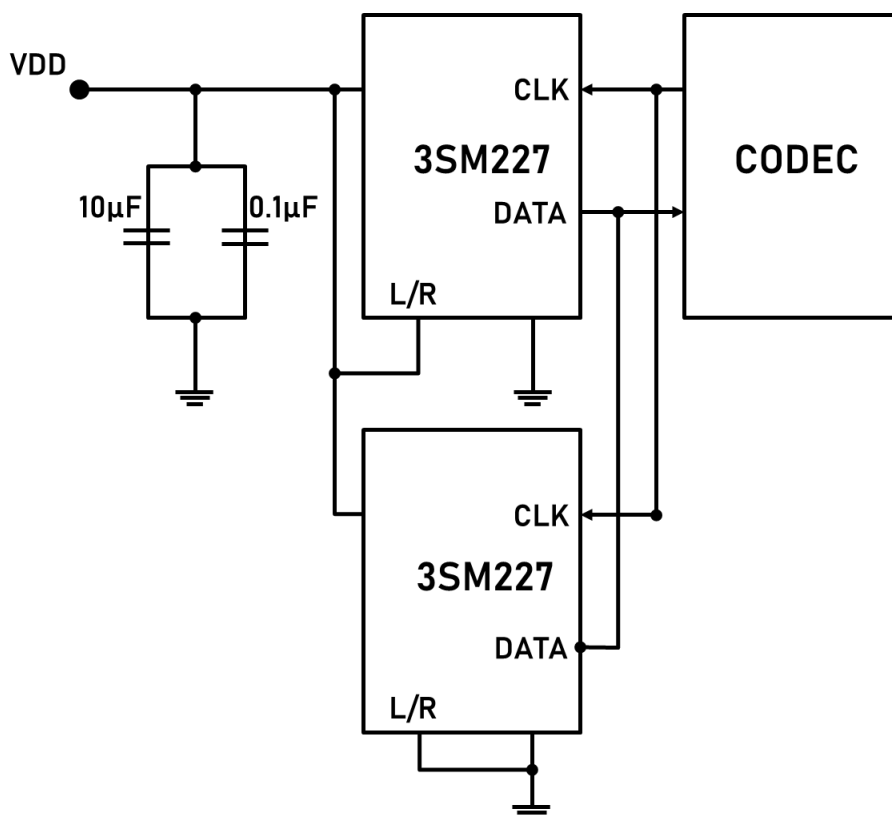

Handling Instructions

The MEMS microphone IC can be handled using standard pick-and-place and chip shooting equipment. Care should be taken to avoid damage to the MEMS microphone IC structure as follows:

- Do not apply vacuum nozzle over the acoustic port (AP) of the microphone to avoid damage to the device.
- Do not blow air directly into acoustic port.
- Brushing the board with/without solvents may damage the device.
- Do not use excessive force to place the microphone on the PCB.
- In case of manual handling, it should be handled with plastic tweezers to avoid damage the device.

Dimensions

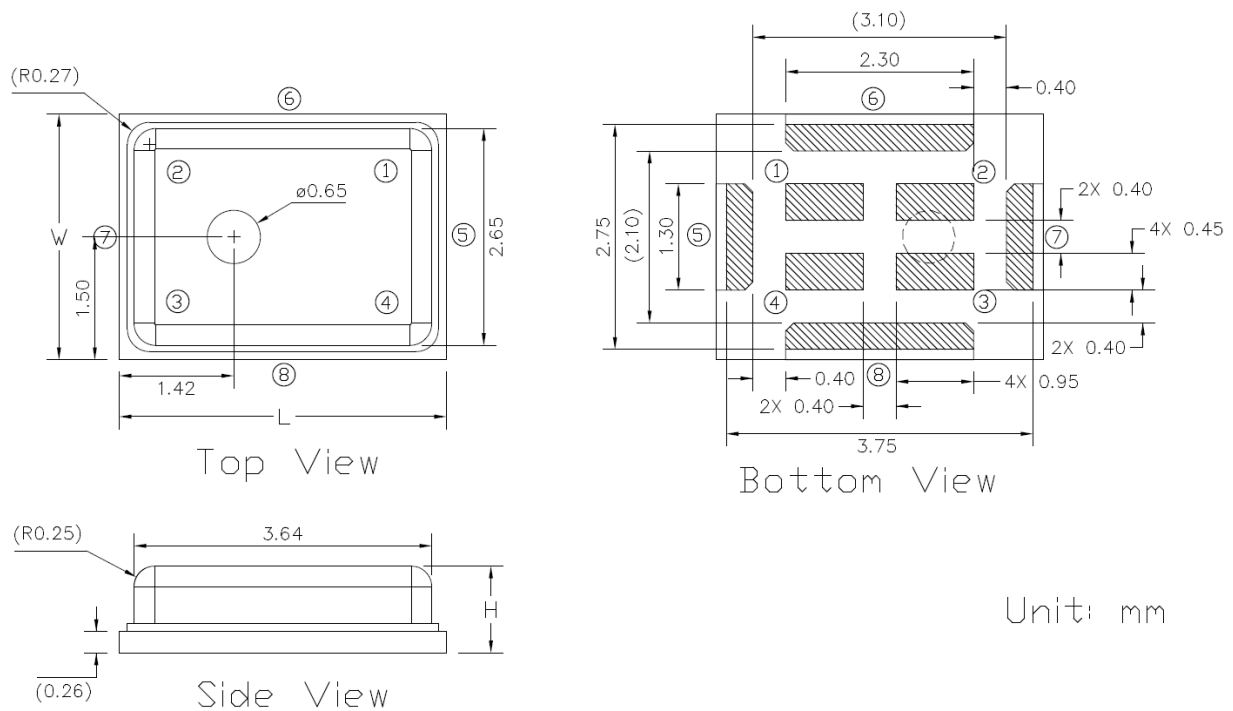
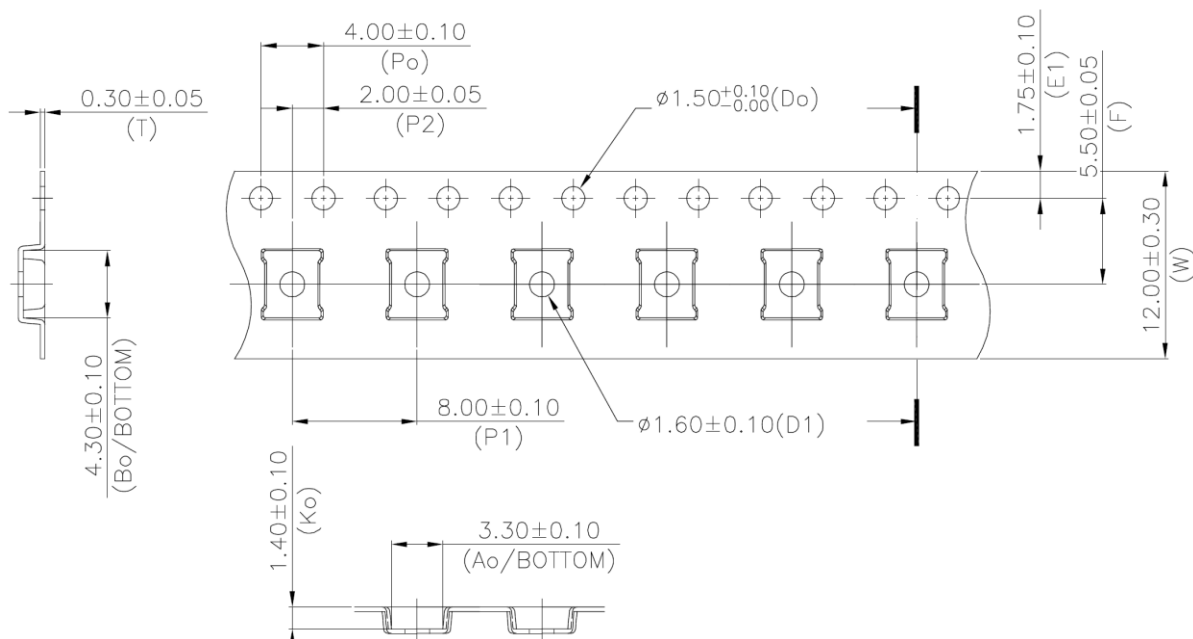

Table 11. (Top View)

Item	Dimension	Tolerance
Length (L)	4.00 mm	± 0.10 mm
Width (W)	3.00 mm	± 0.10 mm
Height (H)	1.06 mm	± 0.10 mm
Acoustic Port	$\Phi 0.65$ mm	± 0.05 mm

Package Information

Carrier Tape:



1. 10 sprocket hole pitch cumulative tolerance ± 0.20 .
2. Carrier camber is within 1 mm in 250 mm.
3. Material : Black Conductive Polystyrene Alloy.
4. All dimensions meet EIA-481 requirements.
5. Thickness : 0.30 ± 0.05 mm.
6. MSL(Moisture sensitivity level) Class1.

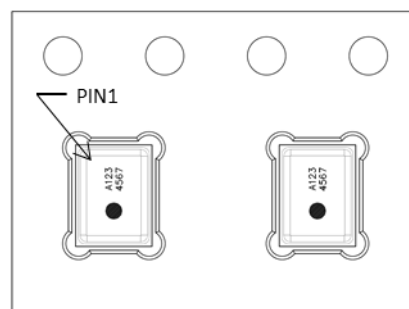

Laser Marking:

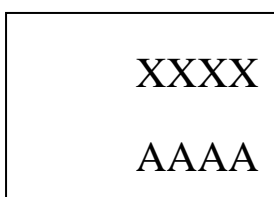

Laser marking on the top side

XXXX	Internal Tracking Code
AAAA	Lot Tracking Code

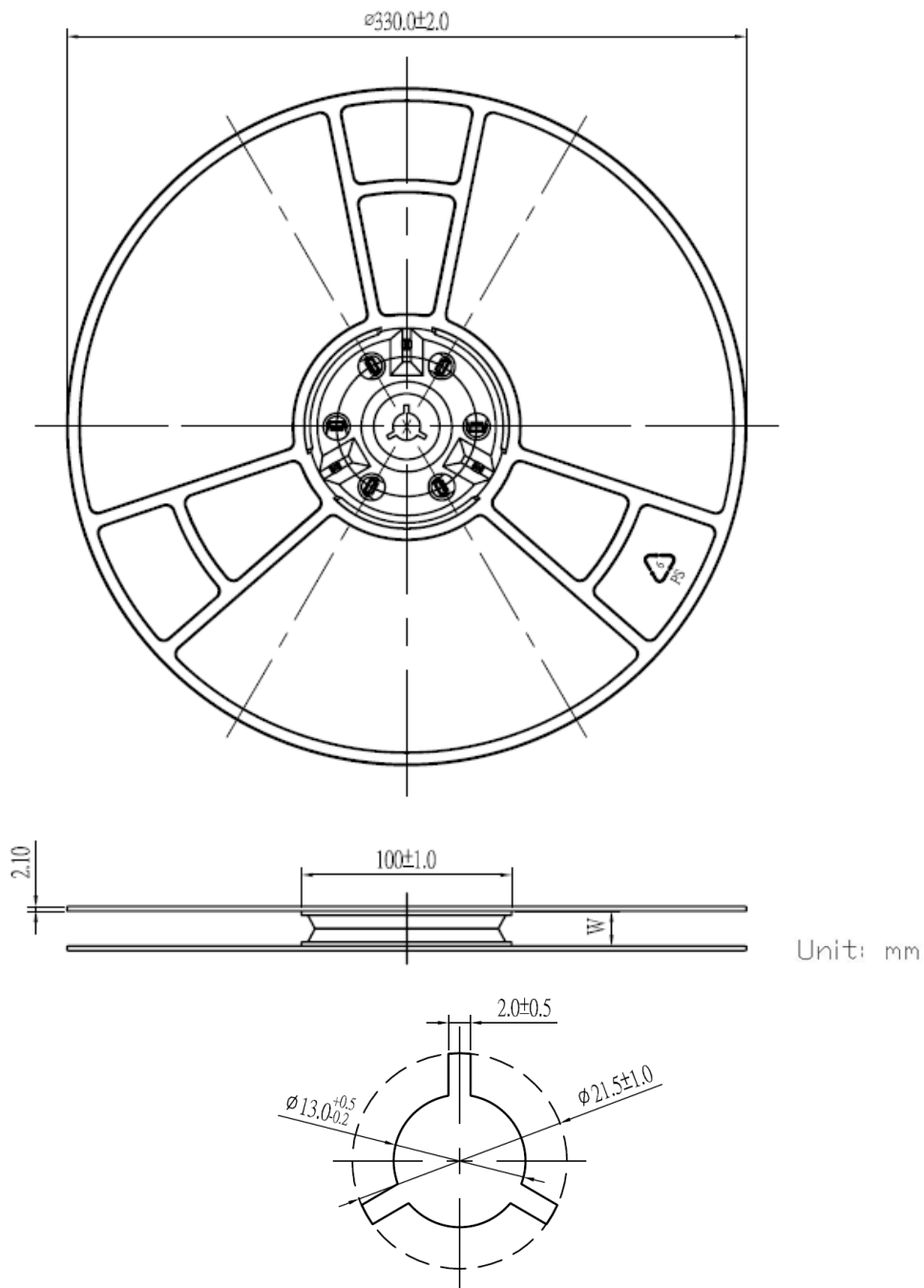
13" Tape Reel :

Model Number	Reel Diameter	Quantity Per Reel
3SM227FMT1KA	13"	5,000

Revision History

Revision	Date	Description
1.0	2023/06/06	Formal release